

HP14X117 BEAM
(FOR REFERENCE ONLY,
NOT INCLUDED)

SET SCREW
X2

STEEL FRAME
(SHOWN WITHOUT
WELDS)

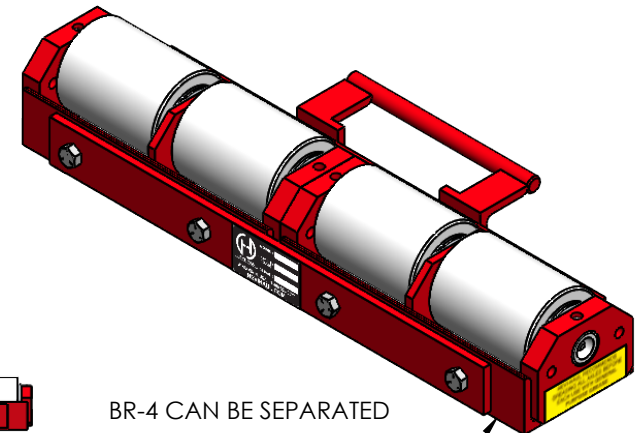
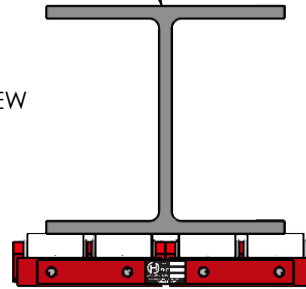

BR-4 CAN BE SEPARATED
AND USED AS 2X BR-2, RATED AT 6
TONS CAPACITY PER SKATE
(CONTACT US FOR INSTRUCTIONS)

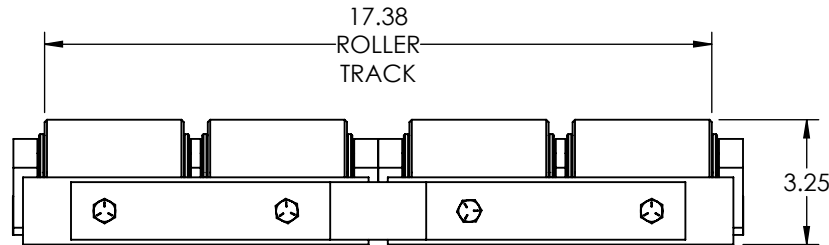

Ø2.75
STEEL ROLLERS
X4

GREASE POINT
X2

REMOVABLE
HANDLE

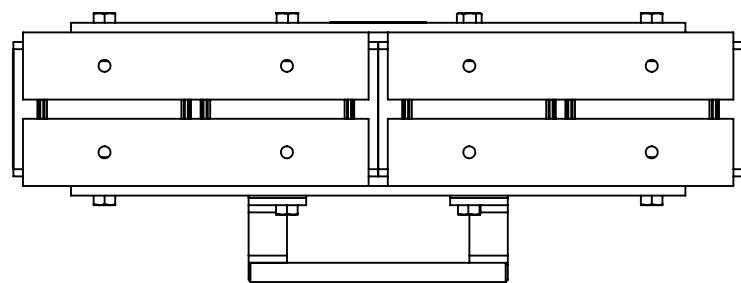
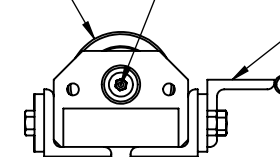

Capacity: 12 Tons Each
Roller Material: Steel
Weight: 43 lbs.
Colorway: Hevi-Haul Red
Country of Origin: United States of
America

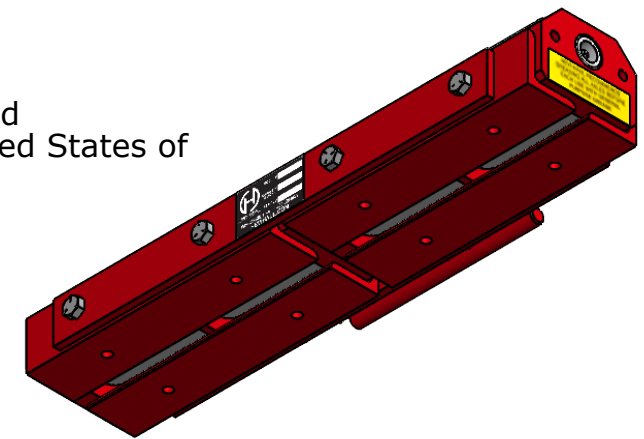

**PLEASE CONTACT US BY PHONE OR
EMAIL IF YOU WOULD LIKE US TO
MODIFY THIS DESIGN. DRAWING IS
SHOWN WITHOUT WELDS.**



HEVI-HAUL
PRODUCTS THAT MOVE THE WORLD
PO Box 580 Menomonee Falls, WI 53052
Phone (262) 502-0333 | hevihaul.com

PROPRIETARY AND CONFIDENTIAL, THE INFORMATION CONTAINED IN THIS DRAWING IS THE SOLE PROPERTY OF HEVI-HAUL. ANY REPRODUCTION IN PART OR AS A WHOLE WITHOUT THE WRITTEN PERMISSION OF HEVI-HAUL IS PROHIBITED.

DIMENSIONS ARE IN INCHES		THIRD ANGLE PROJECTION		DESCRIPTION:		REV:
				SPECIFICATION SHEET		-
SCALE:	DRAWN BY:	DATE:	DWG NO:	SHEET:		
NTS	DMK	3/25/2025	BR-4	1 OF 1		