

HM-50 TOP AND BOTTOM ASSEMBLIES CAN BE SEPERATED WITH A HEX KEY OR IMPACT WRENCH AND USED AS INDIVIDUAL SKATES WITH LINEAR MOVEMENT AND 50 TONS OF CAPACITY PER HALF

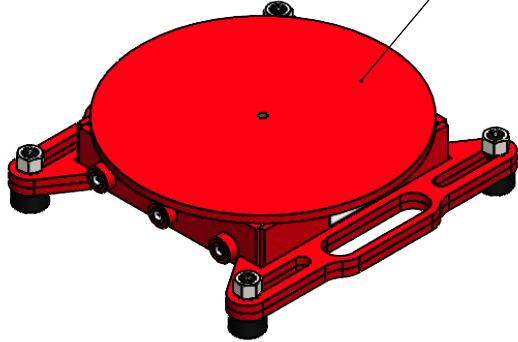

**Capacity:** 50 Tons Each  
**Roller Material:** Steel  
**Weight:** 318 lbs.  
**Colorway:** Hevi-Haul Red  
**Country of Origin:** United States of America

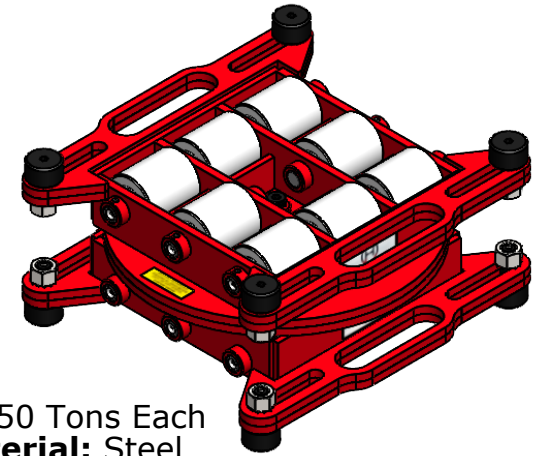
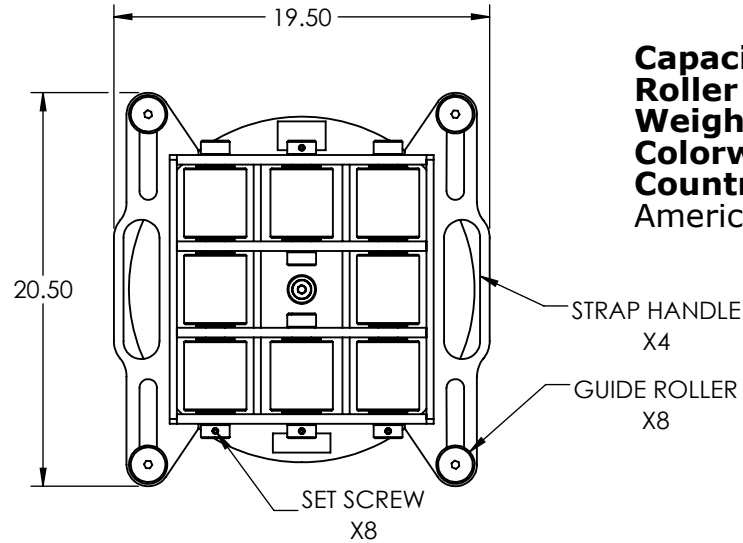

ADJUSTABLE WIDTH GUIDE ROLLER SYSTEM

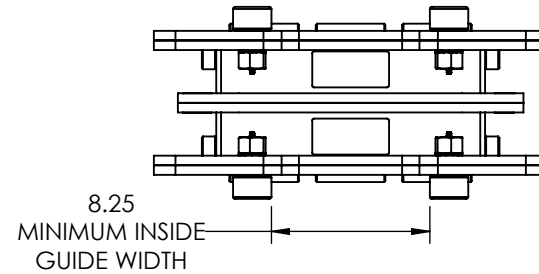
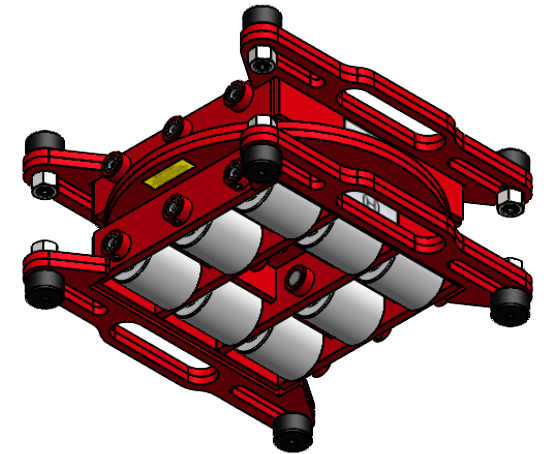
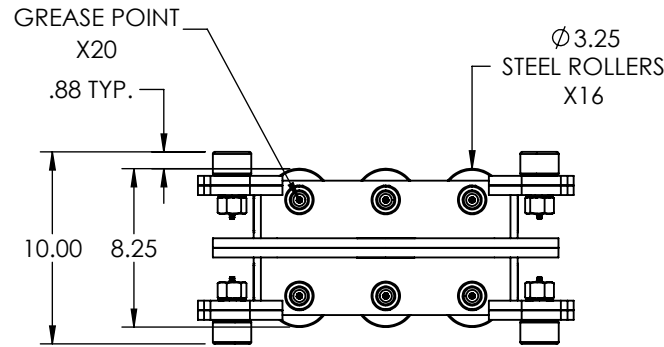
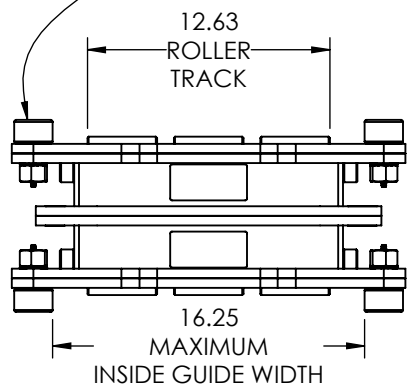

**PLEASE CONTACT US BY PHONE OR EMAIL IF YOU WOULD LIKE US TO MODIFY THIS DESIGN. DRAWING IS SHOWN WITHOUT WELDS.**



**HEVI-HAUL**  
 PRODUCTS THAT MOVE THE WORLD  
 PO Box 580 Menomonee Falls, WI 53052  
 Phone (262) 502-0333 | hevihaul.com

PROPRIETARY AND CONFIDENTIAL, THE INFORMATION CONTAINED IN THIS DRAWING IS THE SOLE PROPERTY OF HEVI-HAUL. ANY REPRODUCTION IN PART OR AS A WHOLE WITHOUT THE WRITTEN PERMISSION OF HEVI-HAUL IS PROHIBITED.

|                          |           |                        |         |                            |  |      |
|--------------------------|-----------|------------------------|---------|----------------------------|--|------|
| DIMENSIONS ARE IN INCHES |           | THIRD ANGLE PROJECTION |         | DESCRIPTION:               |  | REV: |
|                          |           |                        |         | <b>SPECIFICATION SHEET</b> |  | -    |
| SCALE:                   | DRAWN BY: | DATE:                  | DWG NO: | SHEET:                     |  |      |
| NTS                      | DMK       | 3/25/2025              | HM-50   | 1 OF 1                     |  |      |